

MARS 900

TECHNICAL DATA



HIGHLIGHTS

- Compact design enabling trouble-free installation and relocation
- V-shaped table top
- Sloped front
- Excellent light distribution
- Electrical sliding front window
- Easy window cleaning on both sides

For more information please visit
www.labogene.com

Details

Product family	MARS
Model:	900
Product type	Class II Biological Safety Cabinet according to EN 12469
Certificates	None
Compliance with	EN 12469, EN 61010-1, EN 61000-6, EN 11201
e-catalogue classification (UNSPSC code)	411035 Laminar flow cabinets or stations

General specifications	Unit		Note
Sound Pressure Level at factory settings	dB(A)	≤45	According to EN 11201
Sound Pressure Level in Eco-Save mode	dB(A)	≤36	Optional automatic mode shift available
Down flow, Air velocity	m/s	0,28 ± 0,01	Factory setting according to EN 12469
Inflow, Air velocity	m/s	0,45	Factory setting according to EN 12469
Exhaust, Air flow rate	m³/h	292	Factory setting according to EN 12469
Light illuminance (fluorescent tube)	Lux	> 1000	Optionale dimmable version available
Front Opening (height)	mm	200	Factory setting (adjustable between 0-300mm)
Number of table top segments		3	Customized layout and accessories upon request
Filter construction in accordance with EN 1822-1		2-filter system, HEPA, at least Class H14	Class U17 available with MARS PRO 3-filter version
Table top and trough material		AISI 304 stainless steel	Optional AISI 316 stainless steel available
Table top max. total load	kg	100	
Side glass material		5 mm hardened glass w. 3 x ø22mm holes	Other hole options available
Front glass material		6mm laminated safety glass	Optional antireflex coating available
Cabinet and backwall material/colour		Polyester coated steel/RAL 9016	Other RAL colours available upon request

Dimensions	Unit		Note
External dimensions with adjustable stand (Std. height) (DxWxH)	mm	797 x 1004 x 2033	See drawing for details. Can pass through a standard door opening size 9x21M. Stand is available as an option
Table top height with adjustable stand (Std. height)	mm	750 (Range 745-780)	2 additional stand heights available as options
External dimensions with elec. elevation stand (DxWxH)	mm	797 x 1004 X 2025-2325	Available as an option
Table top height with elec. elevation stand	mm	750-1050	
Work chamber dimensions (DxWxH)	mm	650x900x700	
Net weight	kg	157	
Shipping volume	m³	Approx. 2,2	

MARS 900

TECHNICAL DATA

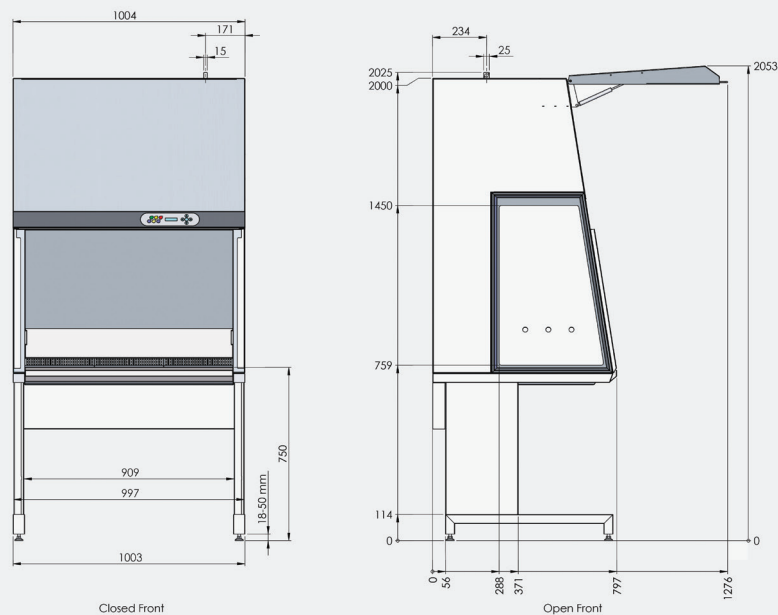

Electrical data	Unit		Note
Rated AC Voltage/frequency	V/Hz	220-240/50-60	Other voltages available
Rated max. current (fuse)	A	10	
Power outlet(s) max. total current (fuse)	A	6,3	The sum of all power outlets
Type of power outlet socket, pair, left & right side		DK - type K (IP44)	Other types available. Select between 9 different regional types
Typical power consumption excl. power outlets	VA/Watt	78/72	At factory setting and normal operation
Typical power consumption in Eco-Save mode	VA/Watt	30/25	
Type of mains connection		3pin male type IEC320 C14	Top mounted, left or right side

Additional available options	Unit		Note
Electrical elevation - Worktop height range	mm	745-1050	
LED light		Excellent neutral white light distribution 1500Lux/4000K	Optionale dimmable version available
UV-C sterilisation		Easy and fast decontamination	
Extra Power outlets, pair, left & right side		Select between 9 different regional types	
Antiblow back valve straight Ø 200 mm			
Antiblow back valve side Ø 200 mm			
Programmable output module for external control purposes		4 sets of potential less contacts	
Hydrogen Peroxide Vapour (VHP) Decontamination valves			

LaboGene ApS is Certified according to EN/ISO 9001 UKAS
 Labogene ApS owns the copyright of this data sheet. Subject to technical changes.
 Illustrations may contain options and modifications not supplied as standard.

LaboGene ApS
 Industrivej 6-8
 DK-3540 Lyngø

Tel (+45) 3940 2566
 Fax (+45) 3995 2566
 Mail info@labogene.com
 Web www.labogene.com

